

C. E. PEASE.
LATHE CHUCK.

No. 470,075.

Patented Mar. 1, 1892.

Fig. 1.

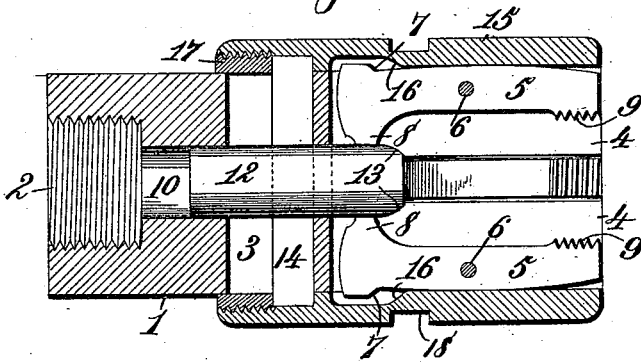

Fig. 2.

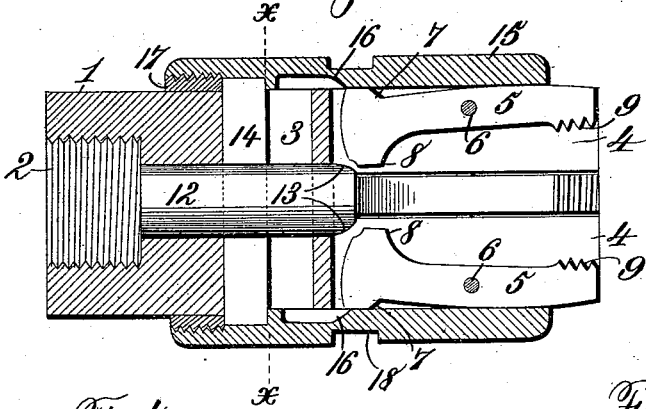

Fig. 4.

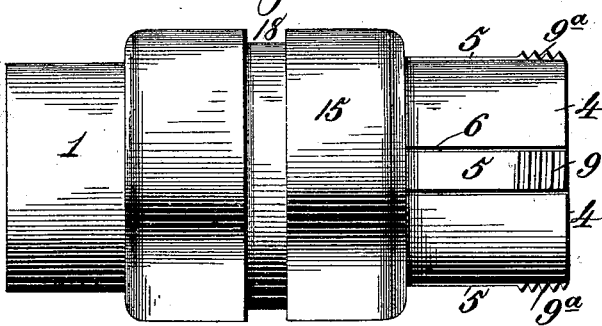
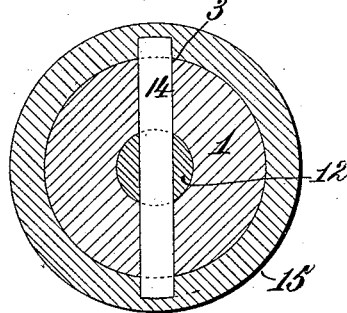

Fig. 5.



Witnesses:
Jas. Hutchinson
Dennis Sumbly

Inventor:
Calvin E. Pease
 By *James L. Norris*
 Attorney

C. E. PEASE.
LATHE CHUCK.

No. 470,075.

Patented Mar. 1, 1892.

Fig. 5.

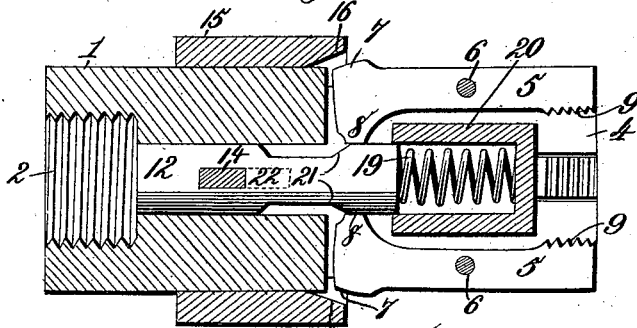

Fig. 6.

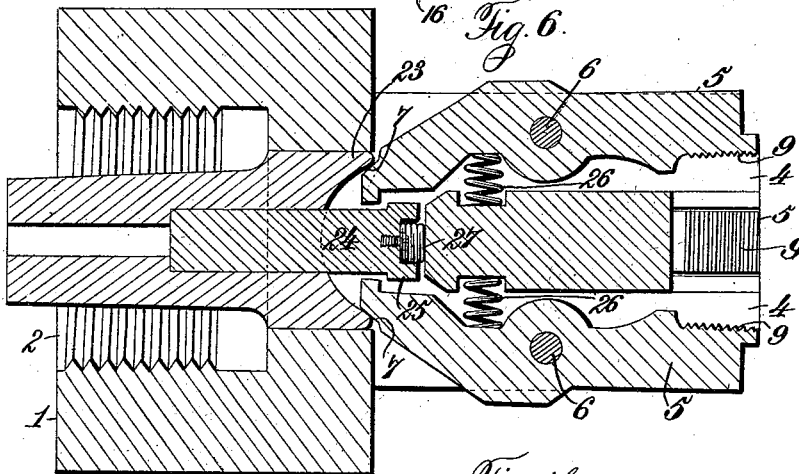
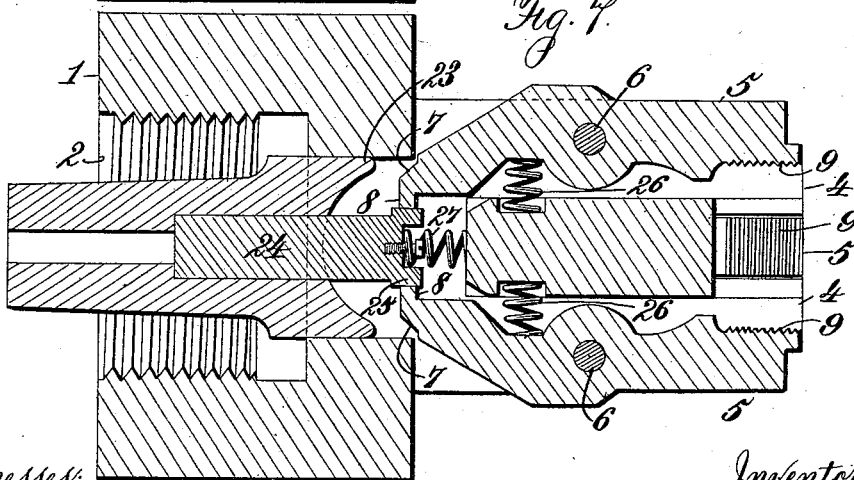

Fig. 7.



Witnesses:
Jas. Hutchinson.
Dennis Sully.

Inventor
Cabin C. Pease.
By James L. Norris Attorney

UNITED STATES PATENT OFFICE.

CALVIN E. PEASE, OF DAYTON, OHIO.

LATHE-CHUCK.

SPECIFICATION forming part of Letters Patent No. 470,075, dated March 1, 1892.

Application filed July 11, 1891. Serial No. 399,191. (No model.)

To all whom it may concern:

Be it known that I, CALVIN E. PEASE, a citizen of the United States, residing at Dayton, in the county of Montgomery and State of Ohio, have invented new and useful Improvements in Lathe-Chucks, of which the following is a specification.

This invention relates to that type of lathe-chucks for retaining objects in a lathe while being operated upon by a tool, wherein oscillatory chuck-jaws have threaded extremities and are positively oscillated to engage and disengage the object through the medium of an external sliding sleeve.

The objects of my invention are to improve the prior chucks of this character, to provide novel means for positively closing and opening the oscillatory jaws, and to provide a novel chuck wherein the oscillatory jaws are positively closed upon the object by an internal wedge-rod and are opened by an external sliding sleeve which provides a firm backing to the jaws at the point of greatest strain when the jaws are closed upon the object by the wedge-rod.

To accomplish all these objects my invention involves the features of construction and the combination or arrangement of devices hereinafter described and claimed, reference being made to the accompanying drawings, in which—

Figure 1 is a longitudinal central sectional view of a lathe-chuck embodying my invention. Fig. 2 is a similar view showing the parts adjusted to open the oscillatory chuck-jaws. Fig. 3 is a transverse sectional view taken on the line $x x$, Fig. 2. Fig. 4 is a side elevation showing a modified construction of the improved chuck. Fig. 5 is a longitudinal sectional view of another modified construction. Fig. 6 is a longitudinal sectional view of another modification, showing the jaws opened; and Fig. 7 is a similar view of the same, showing the jaws closed.

In order to enable those skilled in the art to make and use my invention, I will now describe the same in detail, referring to the drawings, wherein—

The numeral 1 indicates a chuck-body, having a screw-threaded socket 2 for attaching it to a lathe-spindle in the usual manner. The

chuck-body is provided with a transverse channel or slot 3, and at its forward portion is formed with longitudinal slotted portions 4, in which are pivoted the oscillatory chuck-jaws 5. The pivot-pins 6 of the chuck-jaws are located at or near the central portions thereof, and the rear extremities of the jaws are formed or otherwise provided with outwardly-extending inclined projections 7 and inwardly-projecting heel-pieces 8, while the front extremities of the jaws are provided on their inner surfaces with screw-threads 9 in a manner similar to screw-cutting dies in such manner that when the object to be chucked is held against the closed jaws while the lathe-spindle is rotated the chuck-jaws screw upon such object. This character of chucking-jaws is designed for engaging the exterior of an object; but by arranging the screw-threads on the outer sides of the jaws, as in Fig. 4, at 9^a, they are adapted for chucking female work, as will be obvious. I do not, however, confine myself to the employment of screw-threads 9 on the oscillatory chuck-jaws, for if the chuck be designed for plain work the screw-threads 9 can be omitted.

The chuck-body is provided with an axial bore 10, in which is adapted to longitudinally slide a rod 12, having a wedge-shaped front extremity, as at 13, Figs. 1 and 2, which is designed to move between the heel-pieces 8 of the jaws 5 for closing their threaded extremities 9 upon the object to be chucked.

A transverse bar 14, extending through the transverse slot 3 of the chuck-body, is engaged at its extremities with a sleeve 15, which encircles the forward portion of the chuck-body, and is provided on its inner side with inclines 16 to act upon the inclined projections 7 of the jaws 5 for the purpose of releasing the threaded extremities of the jaws from the object. The bar 14 passes through an orifice in the rod 12 and is retained in proper position by a screw-ring 17, screwed into the rear end portion of the sleeve 15, the construction being such that by sliding the sleeve 15 forwardly to the position indicated by Fig. 1 the front extremity of the rod 12 is caused to act upon the heel-pieces 8, and thereby close the threaded extremities 9 of the jaws 5 upon the object to be chucked. If the

sleeve 15 be slid rearwardly, the rod 12 is carried out of engagement with the heel-pieces 8 of the jaws 5 and the inclines 16 of the sleeve act upon the inclined projections 7 of the jaws, and thereby open the threaded extremities 9 to disengage or release the object. When the sleeve 15 is slid forwardly, as in Fig. 1, such sleeve affords a firm backing to the jaws at the point of greatest strain when they are closed on the object to be operated upon.

The sleeve 15 may be provided with an annular groove 18 to receive a forked lever for the purpose of sliding the sleeve while the chuck is rotating. I do not deem it necessary to illustrate the forked lever, as it is an obvious expedient, and, moreover, I may employ other means for actuating the wedge-rod 12 and sleeve 15 for the purpose of opening and closing the chuck-jaws while the chuck is rotating.

In Fig. 5 I illustrate a spring 19, arranged in a suitable chamber 20 and acting on the front extremity of the wedge-rod 12 for the purpose of moving the latter rearwardly to cause the wedge-shaped portions 21 of the wedge-rod 12 to act on the heel-pieces 8 of the jaws 5 and thereby close their threaded extremities 9 upon the object to be chucked. In the modified construction exhibited by Fig. 5 the sleeve 15 is provided with the inclines 16 at its front extremity to act upon the inclined projections 7 of the jaws 5 for the purpose of opening the jaws to disengage or release the object from the chuck. The sleeve 15 is connected with the wedge-rod 12 by means of a transverse bar 14, substantially the same as described with reference to Figs. 1 and 2. The bar 14 is adapted to move back and forth in a slotted portion of the chuck-body, which slotted portion is indicated by the numeral 22.

In Figs. 6 and 7 the inclines 7 are formed on the rear extremities of the chuck-jaws 5 and are acted upon by a device which, for the sake of harmony in terms, may be termed a "sleeve" 23 for the purpose of opening the jaws, as in Fig. 6. In this construction the internal lengthwise-movable rod 24 is rigidly secured to and moves with the sleeve 23, and at its forward extremity it is provided with an enlarged head 25 to pass between and form a rest for the heel-pieces 8 of the chuck-jaws when the latter are closed upon the object or work. The chuck-jaws are closed by the spring 26 when the sleeve 23 is retracted, as in Fig. 7, so that the enlarged head 25 will serve as abutments for the heel-pieces 8, and thereby rigidly hold the chuck-jaws in their closed position upon the object or work.

A spring 27 may be arranged to act on the rod 24 for the purpose of automatically moving it rearward, and the sleeve 23 may be operated in any suitable manner, but preferably by a rod running through the lathe-spin-

dle, which, however, I do not deem it necessary to illustrate, since devices for operating the sleeve will readily suggest themselves to those skilled in the art.

It will be observed that in each of the constructions described the sleeve acts on the inclines 7 to swing the chuck-jaws 5 in the direction required to release them from engagement with the object which has been operated upon by the lathe-tool, while the internal rod on the contrary acts to move the chuck-jaws in the direction required to grip such object.

Having thus described my invention, what I claim is—

1. The combination, with a chuck-body, of oscillatory chuck-jaws having inclines and heel-pieces at their inner extremities, a sleeve for acting on the inclines for moving the chuck-jaws in the direction required to release the object which has been operated on by the lathe-tool, and an internal lengthwise-movable rod for acting on the heel-pieces, substantially as described.

2. The combination, with a chuck-body and oscillatory chuck-jaws, of an internal longitudinally-sliding wedge-rod and an external longitudinally-sliding sleeve connected with the internal wedge-rod and operating on the chuck-jaws to positively move them from engagement with the object which has been operated upon in the lathe, substantially as described.

3. The combination, with a chuck-body, of oscillatory chuck-jaws having at their inner ends outwardly-extending projections and inwardly-extending heel-pieces, a lengthwise-movable wedge-rod for acting on the heel-pieces, an external sleeve encircling the chuck-body and having inclines to act on the outwardly-extending projections of the jaws to move the latter in the direction required to release them from the object which has been operated upon in the lathe, and means for moving the sleeve and wedge-rod in unison, substantially as described.

4. The combination, with a chuck-body, of oscillatory chuck-jaws having their rear extremities provided with outwardly-extending inclined projections and inwardly-extending heel-pieces, an internal longitudinally-sliding wedge-rod for acting upon the heel-pieces, and an external longitudinally-sliding sleeve connected with the wedge-rod and having inclines for acting on the outwardly-extending projections of the jaws, substantially as described.

In testimony whereof I have hereunto set my hand in presence of two subscribing witnesses.

CALVIN E. PEASE.

Witnesses:

J. S. McMAHON,
EZRA M. KUHN.